

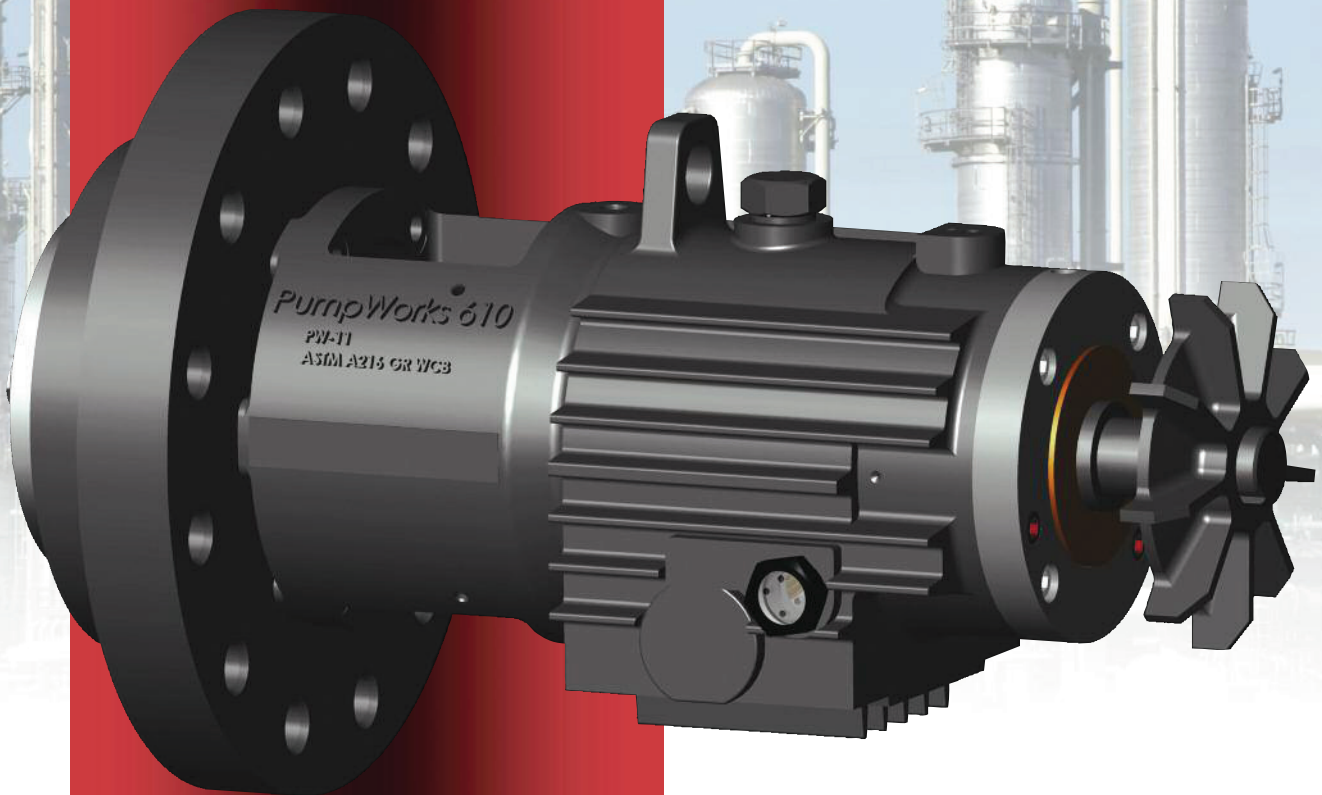

PW-11

**API 610
SINGLE STAGE OH2
UPGRADE PROGRAM**



PW-11 API 610 OH2 UPGRADE PROGRAM

PW-11 is PumpWorks 610 power end retrofit upgrade kit that meets API 610 current edition for horizontal single stage OH2 process pumps. The kit ensures petroleum refineries have a fast and cost-effective way to upgrade any brand of existing OH2 pump and achieve API 610 current edition requirements without expensive changes to the wet end (casing & impeller) and piping.

PW-11 incorporates many new features designed to enhance the reliability, serviceability and parts interchangeability. PumpWorks 610 still preserves the simple maintenance philosophy that has been the cornerstone of the product line since first introduced in 2003.

Some of the more important product updates include:

- Oversized oil fill and vent cap for ease of maintenance
- Lifting lug integrally cast into the steel bearing housing for safe removal of back pullout assembly
- 1" sight glass located on both sides of bearing housing allows viewing of oil level from either side of the pump
- Non-metallic Viton oil flinger disk to assure effective lubrication
- PW-11 Exclusive "SMART LUBE SYSTEM": The innovative oil mist conversion kit allows user to convert to PURE OIL MIST without removing pump from service! Other designs require you to pull the unit and plug thrust bearing "drain back" ports when converting from Oil Sump to Oil Mist. The PW-11 "SMART LUBE SYSTEM" utilizes a precision tolerance, elongated port plug to eliminate oil mist "leakage" around bearings. This ensures proper lubrication and limited downtime. Conversion time is less than 5 minutes.

Scope of Work

- Disassemble, clean and inspect casing and impeller
- Skim suction and discharge flanges
- Skim casing fit or weld up / machine if necessary
- Skim casing gasket fit and cover flange face
- Chase all tapped ports
- Manufacture new shaft (standard 410 SS), casing cover (standard carbon steel), stuffing box bushing (standard 420 SS), impeller nut and retaining ring (standard 316L SS)
- Cast finned WCB carbon steel bearing housing
- INPRO™ bronze VBX bearing isolators
- Non-metallic oil flinger
- SKF™ Explorer series radial and thrust bearing
- Impeller wear rings (standard 420 SS)
- Casing and stuffing box wear rings (standard 410 SS)
- Casing gasket (Graphoil filled VMC 304 SS)
- Dynamically balance rotor
- Assemble pump
- Install mechanical seal and air test for 30 minutes
- Paint
- Package for shipment
- Installation, operation and maintenance manual
- Optional material combinations, bearing isolators, bearing lubrication, and bearing assembly (cooling)
- Optional non-witnessed or witnessed performance test per API 610

Materials

Other material combinations are available.

Pricing and Delivery Options

OPTION #1 (Complete Package)

Send your pump in for complete hydraulic review and upgrade. Delivery 2-3 weeks.

OPTION #2 (Hardware, Machining & Engineering)

Complete a simple pump documentation form and we'll provide a finished back pull out assembly for customer to install on site along with the machining instructions for casing and impeller. Delivery 2-3 weeks.

OPTION #3 (Hardware, with Engineering)

Purchase upgrade kit with engineering support for machining drawings, and casing/impeller machine work. All part drawings are furnished. Allows flexibility for customer to provide their own machining and assembly labor. Delivery 1-2 weeks.

OPTION #4 (Hardware Only)

Purchase upgrade kit and receive ship loose parts and components for machining and assembly. Delivery 1 day.

OPTION #5 (Zero Downtime)

With access to over 1200 single stage OH2 overhung surplus/used pumps in STOCK to match customers identical unit. Upgrading the surplus/used pump out of inventory to drop in place. Utilizing existing casing and impeller with PumpWorks 610 PW-11 retrofit upgrade kit. Delivery 4 weeks.

PWH API 610 Process Pump

PWH is the PumpWorks 610 API 610 current edition overhung OH2 process pump in API 610 material classes S-6, S-8, C-6 and A-8. Other material combinations are available. The pumps are built, assembled and performance tested in full compliance with API 610 in Tyler, Texas USA.

What differentiates PumpWorks 610 model PWH from the competition:

- Shorter lead times – 16 weeks for API 610 Material Classes S-6, S-8 and C-6
- Manufactured and tested in the United States
- Access for end users and specifiers to select, configure and price their pump application on line at www.pumpworks610.com



See our PWH API 610 Single Stage OH2 Brochure for more information.

DESIGN FEATURES & BENEFITS

Impeller Retention

- Keyed and secured to shaft with exclusive dual set-screw locknut

Casing Cover and Seal Chamber

- API 610 seal chamber allows user to install any API 682 cartridge seal to meet process requirements
- Renewable throat bushing for controlled seal chamber environment
- Flat surface seal gland for O-Ring sealing
- Optional machined gasket area for higher temperature applications or on customers request

Renewable Casing and Impeller Wear Rings

- Front and back rings control seal chamber pressure and provides impeller stability
- Optional non-metallic rings for improved efficiency and dry running

Heat Sink

- Precision machined aluminum heat sink allows pump to operate on process temperature up to 400° F without additional cooling

Bearing Lubrication

- Oil mist ports for pure or purge lubrication are standard and located on outboard side of each bearing to ensure positive oil mist flow through each bearing

Lifting Lug

- Integrally cast lifting lug for safe removal of back pullout assembly

Oversized Fill Cap

- 1" oil fill and vent cap for easy maintenance

Bearing Housing

- 3 sizes cover the entire product line for maximum parts interchangeability
- Cast finned WCB carbon steel for improved heat dissipation
- Internally coated to reduce contamination
- Large oil sump capacity

Quality

- Manufactured and tested in the USA

Bearing Assembly

- Optional precision machined aluminum outboard cooling fan for process temperature up to 700° F
- Optional water cooling with finned cooler available in copper or 316 SS for process temperatures to 800° F

Two Oil Sight Glasses

- 1" sight glass located on both sides of bearing housing allows viewing of oil level from either side of pump

Bearing Lubrication

- Non-metallic Viton oil flinger disk to assure effective lubrication
- Eliminates oil contamination issues common with bronze "Slinger Rings"

Labyrinth Oil Seal

- INPRO™ bronze VBXXD bearing isolators to provide optimum bearing housing environment
- Optional magnetic isolators available with expansion chamber

Zero Downtime Oil Mist Conversion

- PW-11 Exclusive "SMART LUBE SYSTEM": The innovative oil mist conversion kit allows user to convert to PURE OIL MIST without removing pump from service! Other designs require you to pull the unit and plug thrust bearing "drain back" ports when converting from Oil Sump to Oil Mist. The PW-11 "SMART LUBE SYSTEM" utilizes a precision tolerance, elongated port plug to eliminate oil mist "leakage" around bearings. This ensures proper lubrication and limited downtime. Conversion time is less than 5 minutes.

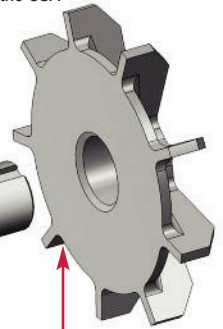
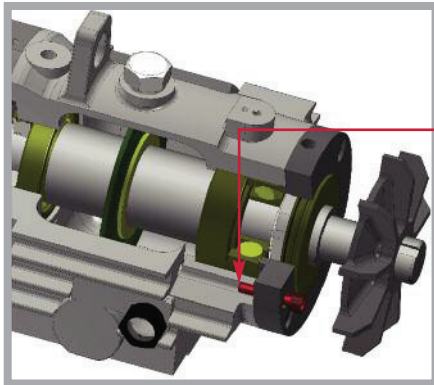

TECHNICAL DATA

GROUP		I	II	III
SHAFT	Diameter at Coupling [IN]	1.625	2.000	2.375
	Keyway at Coupling [IN]	0.375	0.500	0.500
	Extension at Coupling [IN]	3.500	3.500	4.500
	Diameter at Mechanical Seal [IN]	1.999	2.749	3.374
	Diameter Between Bearings [IN]	3.000	3.500	4.250
	Distance Between Bearings [IN]	7.688	8.813	9.750
	Radial Bearing	6212	6215	6218
	Thrust Bearing	7312 x 2	7314 x 2	7317 x 2
	Maximum HP/100 RPM	8.0	12.5	24.0
	Maximum Impeller Diameter [IN]	10.5	14.5	21.5
MAX. TEMP.	No Cooling	400° F	400° F	400° F
	Outboard Fan	700° F	700° F	700° F
	Water Cooled	800° F	800° F	800° F

Test Facility Horizontal and Vertical Pumps

A critical function of any pump manufacturer is the performance testing of their product across the pump's operating region to ensure that it meets design specifications. The PumpWorks 610 Pump Test Facility at the 110,000 square foot manufacturing plant in Tyler, Texas USA is designed to provide performance and NPSHR tests in accordance with the latest edition of API 610.

Comprehensive Performance Test
A critical function of any pump manufacturer is the performance testing of their product across the pump's operating region to ensure that it meets design specifications. The PumpWorks 610 Pump Test Facility at the 110,000 square foot manufacturing plant in Tyler, Texas USA is designed to provide performance and NPSHR tests in accordance with the latest edition of API 610.

TEST FACILITY CAPABILITIES:

- Discharge up to 7500 gpm
- Discharge test pressures up to 2000 psi
- Variable frequency drive for precise speed control through 600 HP @ 460 volt
- Solid state soft start for low impact motor starting over 600 HP through 2000 HP @ 4160 volt

See our PumpWorks 610 Test Facility Brochure for more information.

turbine pump in API 610 material classes S-1, S-4, S-5, S-8 and A-8. Other material combinations are available. The pumps are built, assembled and performance tested in full compliance with API 610 in Tyler, Texas USA.

What differentiates PumpWorks 610 model PWV from the competition:

- Shorter lead times – 16 weeks in API 610 Material Class S-1
- Manufactured and tested in the United States
- Access for end users and specifiers to select, configure and price their pump application on line at www.pumpworks610.com

See our *PWV API 610 Vertical Turbine VS6 (Can Type) and VS1 (Sump Type) Brochure for more information.*

Visit our web site at www.pumpworks610.com and specify flow and performance needs and obtain pump selection, performance curve, drawing, data sheet, and pricing through ePOD software pump selection program.

See our *PumpWorks 610 Company Profile Brochure for more information.*

Re-Rate

Along with the PW-11 upgrade, a hydraulic re-rate can further increase service life. Re-rate performed on customer equipment are normally driven by changes in an existing process, a re-application of the equipment, and to improve the MTBR.

PWV API 610 Vertical Turbine Pump

PWV is the PumpWorks 610 API 610 current edition VS6 and VS1 vertical



PumpWorks 610 • www.pumpworks610.com

8885 Monroe • Houston, TX 77061 • Ph. 888-405-0209 • Fax 713-956-2141

A DIVISION OF BEST PUMPWORKS • www.bestpumpworks.com